



# Fantech

## HP190SL

Low Profile Radon Fan



Patent Pending

Fantech has utilized its twenty years of experience as a radon fan manufacturer to develop the new HP190SL. This new fan features a patent-pending design starting from its outward low profile appearance to the high efficiency, continuous duty ebm-papst motor and integrated condensate bypass system.

Radon mitigators will appreciate the ease of its direct wall-mount design that eliminates the need for elbows and reduces labor costs.

Unit is UL Listed for wet locations. 5 year warranty.

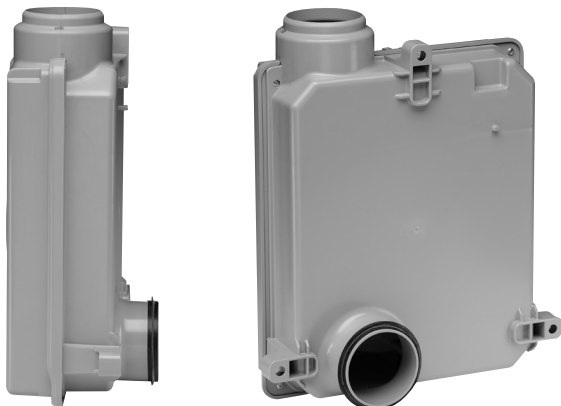

### SPECIFICATIONS

The HP190SL is engineered specifically for the demanding environments of radon mitigation applications.

Low profile, wall-mount design minimizes installation time.

Fan and discharge pipe are located on surface of exterior wall eliminating need for elbows.

Fan connects directly to low pressure pipe opening on exterior wall.

### HOUSING

- Constructed from durable, UV resistant polycarbonate.
- Factory sealed, no leak design.
- Integral condensate bypass.
- Direct wall-mount with integral vibration isolation.

### MOTOR

- High efficiency, continuous duty ebm-papst motor.
- Non-overloading motorized impeller.
- Built-in thermal overload protection.

### ELECTRICAL SPECIFICATIONS

Input Volts  
Amperage

### HP190SL

120VAC 1 Phase  
0.78 Amps



# HP190SL Low Profile Radon Fan

## Dimensions

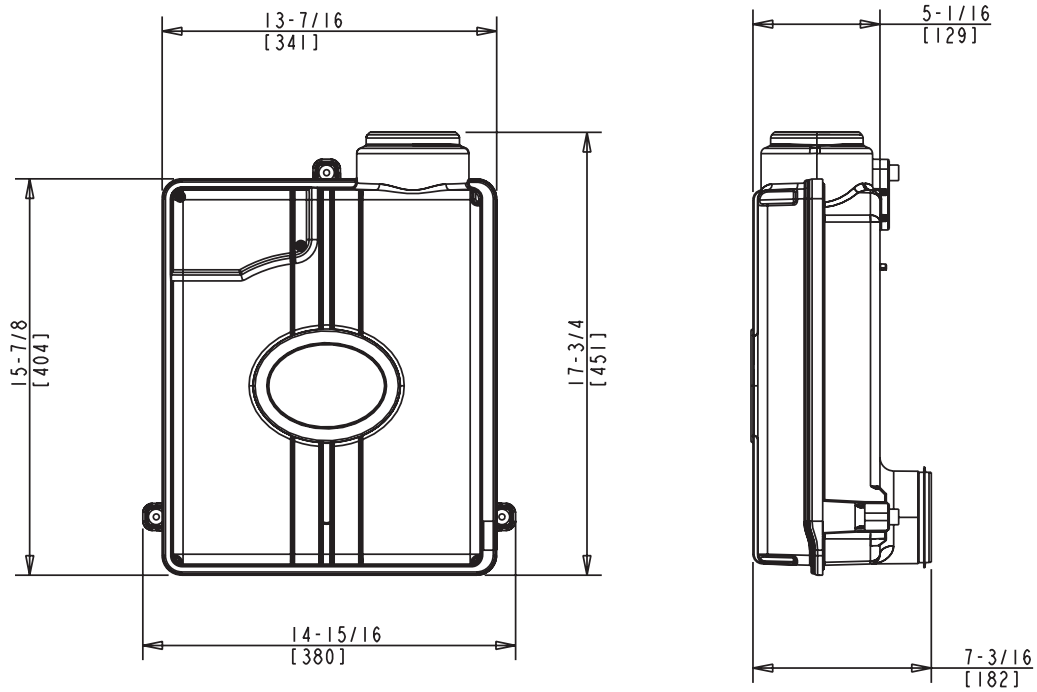

## Fan Performance

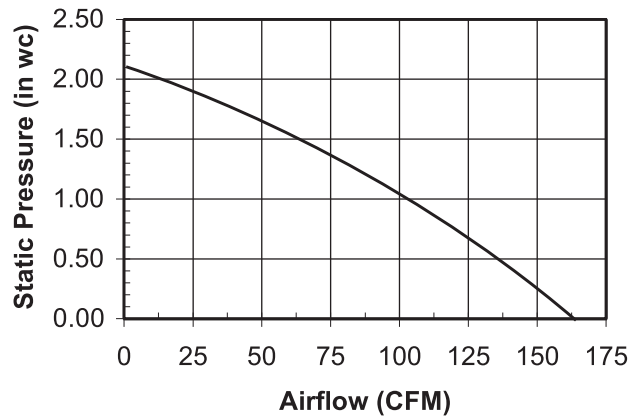

FOR MORE INFORMATION CONTACT:



# Fantech

United States

10048 Industrial Blvd. • Lenexa, KS 66215  
 Phone: 800.747.1762; 913.752.6000  
 Fax: 800.487.9915; 913.752.6466

Canada

50 Kanalfakt Way, Bouctouche, NB E4S 3M5  
 Phone: 800.565.3548; 506-743-9500  
 Fax: 800.747.8116; 506.743.9600

www.fantech.net • info@fantech.net